

HX6408

512k x 8 STATIC RAM

The 512K x 8 Radiation Hardened Static RAM is a high performance 524,288 word x 8-bit static random access memory with optional industry-standard functionality. It is fabricated with Honeywell's radiation hardened Silicon On Insulator (SOI) technology, and is designed for use in low voltage systems operating in radiation environments. The RAM operates over the full military temperature range and requires only a single 3.3 V \pm 0.3V power supply. Power consumption is typically <30 mW @ 1MHz in write mode, <14 mW @ 1MHz in read mode, and is less than 5 mW when in standby mode.

Honeywell's enhanced SOI V technology is radiation hardened through the use of advanced and proprietary design, layout and process hardening techniques.

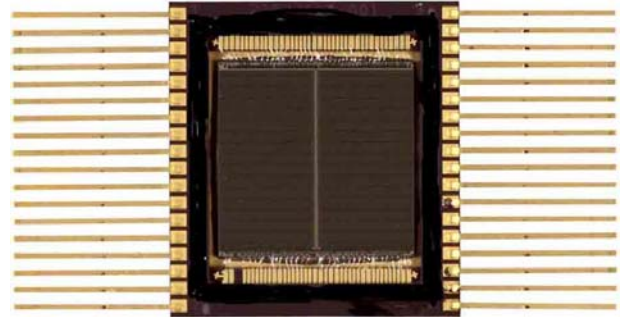

The SOI V low power process is a SOI CMOS technology with an 80 Å gate oxide and a minimum drawn feature size of 0.35 μ m. Additional features include tungsten via and contact plugs, Honeywell's proprietary SHARP planarization process and a lightly doped drain (LDD) structure for improved short channel reliability. A seven transistor (7T) memory cell is used for superior single event upset hardening, while three layer metal power busing and the low collection volume SOI substrate provide improved dose rate hardening.

FEATURES

- Fabricated with SOI V Silicon On Insulator
- 0.35 μ m Process ($L_{eff} = 0.28 \mu$ m)
- Total Dose $\geq 3 \times 10^5$ and 1×10^6 rad(Si)
- Neutron $\geq 1 \times 10^{14}$ cm⁻²
- Dynamic and Static Transient Upset $\geq 1 \times 10^{10}$ rad(Si O₂)/s (3.3 V)
- Dose Rate Survivability $\geq 1 \times 10^{12}$ rad(Si O₂)/s
- Soft Error Rate $\leq 1 \times 10^{-10}$ Upsets/bit-day (3.3 V)
- No Latchup
- Read/Write Cycle Times ≤ 20 ns, (3.3 V), -55 to 125°C
- Typical Operating Power (3.3 V) <14 mW @ 1MHz Read <30 mW @ 1MHz Write <5 mW Standby mode
- Asynchronous Operation
- CMOS Compatible I/O
- Single Power Supply, 3.3 V \pm 0.3 V
- Operating Range is -55°C to +125°C
- 36-Lead Flat Pack Package
- Optional Low Power Sleep Mode

HX6408

FUNCTIONAL DIAGRAM

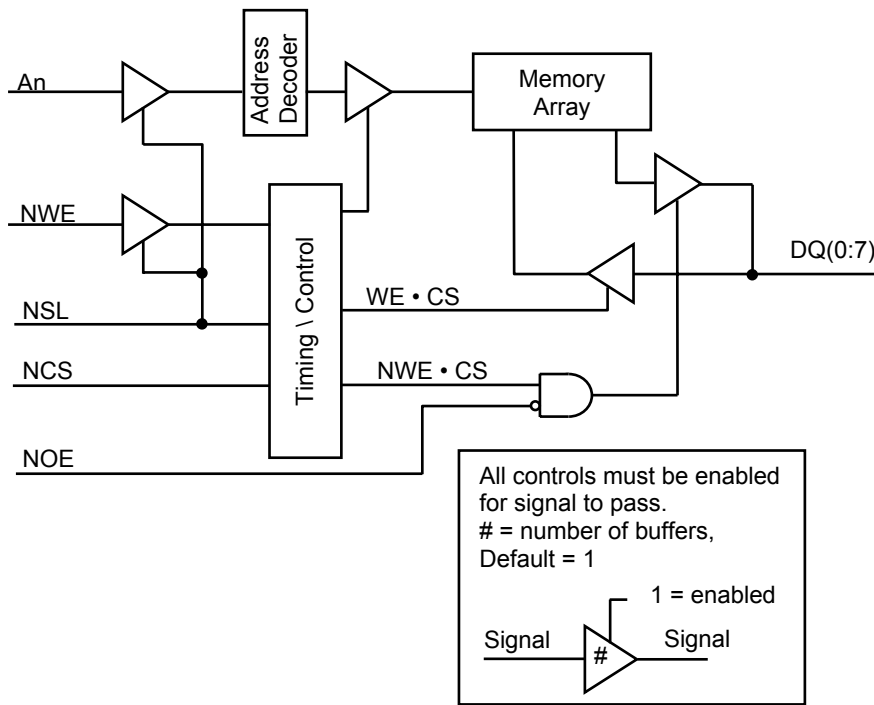

36 LEAD FLAT PACK PINOUT

HX6408 Top View			
A0	1	36	(NSL)
A1	2	35	A18
A2	3	34	A17
A3	4	33	A16
A4	5	32	A15
NCS	6	31	NOE
D0	7	30	D4
D1	8	29	D5
VDD	9	28	VSS
VSS	10	27	VDD
D2	11	26	D6
D3	12	25	D7
NWE	13	24	A14
A5	14	23	A13
A6	15	22	A12
A7	16	21	A11
A8	17	20	A10
A9	18	19	NC*

* = No Connect

SIGNAL DEFINITIONS

- A: 0-18 Address input pins, which select a particular eight-bit word within the memory array.
- DQ: 0-7 Bidirectional data pins, which serve as data outputs during a read operation and as data inputs during a write operation.
- NCS Negative chip select, when at a low level allows normal read or write operation. When at a high level NCS forces the SRAM to a precharge condition, holds the data output drivers in a high impedance state. If this signal is not used it must be connected to VSS.
- NWE Negative write enable, when at a low level activates a write operation and holds the data output drivers in a high impedance state. When at a high level NWE allows normal read operation.
- NOE Negative output enable, when at a high level holds the data output drivers in a high impedance state. When at a low level, the data output driver state is defined by NCS, NWE and NSL. This signal is asynchronous.
- NSL Not sleep, when at a high level allows normal operation. When at a low level NSL forces the SRAM to a precharge condition, holds the data output drivers in a high impedance state and disables all the input buffers except the NCS and NOE input buffers. If this signal is not used it must be connected to VDD. This signal is asynchronous. The HX6408 may be ordered without the sleep mode option and pin 36 is then a NC.

HX6408

TRUTH TABLE

NCS	NSL	NWE	NOE	Mode	DQ
L	H	H	L	Read	Data Out
L	H	L	X	Write	Data In
H	X	X	X	Deselected	High Z
X	L	X	X	Sleep	High Z

X: VI = VIH or VIL,

NOE=H: High Z output state maintained for NCS=X, NWE=X

RADIATION

Total Ionizing Radiation Dose

The SRAM will meet all stated functional and electrical specifications over the entire operating temperature range after the specified total ionizing radiation dose. All electrical and timing performance parameters will remain within specifications. Total dose hardness is assured by wafer level testing of process monitor transistors and RAM product using 10 KeV X-ray. Transistor gate threshold shift correlations have been made between 10 KeV X-rays applied at a dose rate of 1×10^5 rad(SiO₂)/min at T= 25°C and gamma rays (Cobalt 60 source) to ensure that wafer level X-ray testing is consistent with standard military radiation test environments.

Transient Pulse Ionizing Radiation

The SRAM is capable of writing, reading, and retaining stored data during and after exposure to a transient ionizing radiation pulse, up to the specified transient dose rate upset specification, when applied under recommended operating conditions. It is recommended to provide external power supply decoupling capacitors to maintain VDD voltage levels during transient events. The SRAM will meet any functional or electrical specification after exposure to a radiation pulse up to the transient dose rate survivability specification, when applied under recommended operating conditions. Note that the current conducted during the pulse by the RAM inputs, outputs, and power supply may

significantly exceed the normal operating levels. The application design must accommodate these effects.

Neutron Radiation

The SRAM will meet any functional or timing specification after exposure to the specified neutron fluence under recommended operating or storage conditions. This assumes an equivalent neutron energy of 1 MeV.

Soft Error Rate

The SRAM is capable of meeting the specified Soft Error Rate (SER), under recommended operating conditions.

This hardness level is defined by the Adams 90% worst case cosmic ray environment for geosynchronous orbits.

Latchup

The SRAM will not latch up due to any of the above radiation exposure conditions when applied under recommended operating conditions. Fabrication with the SOI substrate material provides oxide isolation between adjacent PMOS and NMOS transistors and eliminates any potential SCR latchup structures. Sufficient transistor body tie connections to the p- and n-channel substrates are made to ensure no source/drain snapback occurs.

HX6408

RADIATION HARDNESS RATINGS (1)

Parameter	Limits (2)	Units	Test Conditions
Total Dose	$\geq 3 \times 10^5$ $\geq 1 \times 10^6$	rad(Si)	$T_A = 25^\circ\text{C}$ Cobalt 60
Transient Dose Rate Upset	$\geq 1 \times 10^{10}$	rad(Si O ₂)/s	Pulse width ≤ 50 ns VDD=3.6V, $T_A = 25^\circ\text{C}$, x-ray
Transient Dose Rate Survivability	$\geq 1 \times 10^{12}$	rad(Si O ₂)/s	Pulse width ≤ 50 ns, X-ray, VDD=3.6V, $T_A = 25^\circ\text{C}$
Soft Error Rate	$< 1 \times 10^{-10}$	Upsets/bit-day	$T_A = 85^\circ\text{C}$, Adams 90% worst case environment
Neutron Fluence	$\geq 1 \times 10^{14}$	N/cm ²	1MeV equivalent energy, Unbiased, $T_A = 25^\circ\text{C}$

(1) Device will not latch up due to any of the specified radiation exposure conditions.

(2) Operating conditions (unless otherwise specified): VDD=3.0V to 3.6V, $T_A = -55^\circ\text{C}$ to 125°C

ABSOLUTE MAXIMUM RATINGS (1)

Symbol	Parameter	Rating		Units
		Min	Max	
VDD	Supply Voltage Range (2)	-0.5	4.6	V
VPIN	Voltage on Any Pin (2)	-0.5	VDD+0.5	V
TSTORE	Storage Temperature (Zero Bias)	-65	150	$^\circ\text{C}$
TSOLDER	Soldering Temperature (5 seconds)		270	$^\circ\text{C}$
PD	Maximum Power Dissipation (3)		2.5	W
IOUT	DC or Average Output Current		25	mA
VPROT	ESD Input Protection Voltage (4)	2000		V
Θ_{JC}	Thermal Resistance (Jct-to-Case)	36 Pin FP	2	$^\circ\text{C/W}$
TJ	Junction Temperature		175	$^\circ\text{C}$

(1) Stresses in excess of those listed above may result in permanent damage. These are stress ratings only, and operation at these levels is not implied. Frequent or extended exposure to absolute maximum conditions may affect device reliability.

(2) Voltage referenced to VSS.

(3) RAM power dissipation (IDDSB + IDDOP) plus RAM output driver power dissipation due to external loading must not exceed this specification.

(4) Class 2 electrostatic discharge (ESD) input protection. Tested per MIL-STD-883, Method 3015 by DSEC certified lab.

RECOMMENDED OPERATING CONDITIONS

Symbol	Parameter	Description			Units
		Min	Typ	Max	
VDD	Supply Voltage (referenced to VSS)	3.0	3.3	3.6	V
TA	Ambient Temperature	-55	25	125	$^\circ\text{C}$
VPIN	Voltage on Any Pin (referenced to VSS)	-0.3		VDD+0.3	V
VDDRAMP	VDD Turn on ramp time			50	ms

HX6408

DC ELECTRICAL CHARACTERISTICS

Symbol	Parameter	Worst Case (1)		Units	Test Conditions
		Min	Max		
IDDSB	Static Supply Current TA=25°C TA=125°C		5 10	mA	VDD=max, Iout=0mA, Inputs Stable
IDDOP3	Static Supply Current Deselected		24	mA	VDD=max, Iout=0mA, f=fmax, NSL=NCS=VIH (2) (3)
IDDOPW	Dynamic Supply Current, Selected (Write) 1 MHz 2 MHz 10 MHz 25 MHz 40 MHz		9 18 89 160 260	mA	VDD=max, Iout=0mA, NSL=VIH, NCS=VIL (1) (3)
IDDOPR	Dynamic Supply Current, Selected (Read) 1 MHz 2 MHz 10 MHz 25 MHz 40 MHz		4 8 40 100 160	mA	VDD=max, Iout=0mA, NSL=VIH, NCS=VIL (1) (3)
IDDOP1	Dynamic Supply Current, Deselected		1.5	mA	VDD=max, Iout=0mA, f=1MHz, NSL=VIH (2) (3)
IDDOP2	Dynamic Supply Current, Sleep		0.2	mA	VDD=max, Iout=0mA, f=1MHz, NSL=VIL (2) (3)
II	Input Leakage Current	-5	5	µA	Vss VI VDD
IOZ	Output Leakage Current	-10	10	µA	Vss VIO VDD output = high Z
VIL	Low-Level Input Voltage		0.3xVDD	V	VDD=3.0V
VIH	High-Level Input Voltage	0.7xVDD		V	VDD=3.6V
VOL	Low-Level Output Voltage		0.4	V	VDD=3.0V, IOL = 8mA
VOH	High-Level Output Voltage	2.7		V	VDD=3.0V, IOH = 4mA

(1) Worst case operating conditions: VDD=3.0V to 3.6V, -55°C to +125°C, post total dose at 25°C.

(2) All inputs switching. DC average current.

(3) All dynamic operating mode current measurements (IDDOPx) exclude standby mode current (IDDSB)

CAPACITANCE (1)

Symbol	Parameter	Worst Case (1)		Units	Test Conditions
		Min	Max		
CI	Input Capacitance		9	pF	VI=VDD or VSS, f=1 MHz
CO	Output Capacitance		8	pF	VIO=VDD or VSS, f=1 MHz

(1) This parameter is tested during initial design characterization only.

HX6408

DATA RETENTION CHARACTERISTICS

Symbol	Parameter	Typical (1)	Worst Case (2)		Units	Test Conditions
			Min	Max		
VDR	Data Retention Voltage		2.0		V	NCS=VDR VI=VDR or VSS
IDR	Data Retention Current			3	mA	NCS=VDD=VDR VI=VRD or VSS

(1) Typical operating conditions: TA=25°C, pre-radiation.

(2) Worst case operating conditions: TA=-55°C to +125°C, post dose at 25°C

TESTER EQUIVALENT LOAD CIRCUIT

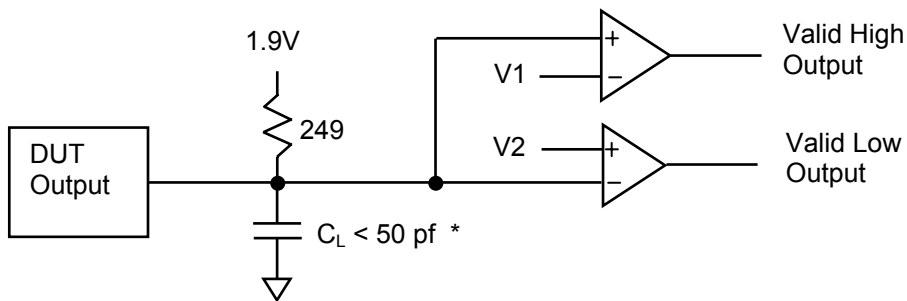

* $C_L = 5\text{pf}$ for TWQZ, TSHQZ, TPLQZ, and TGHQZ

Tester AC Timing Characteristics

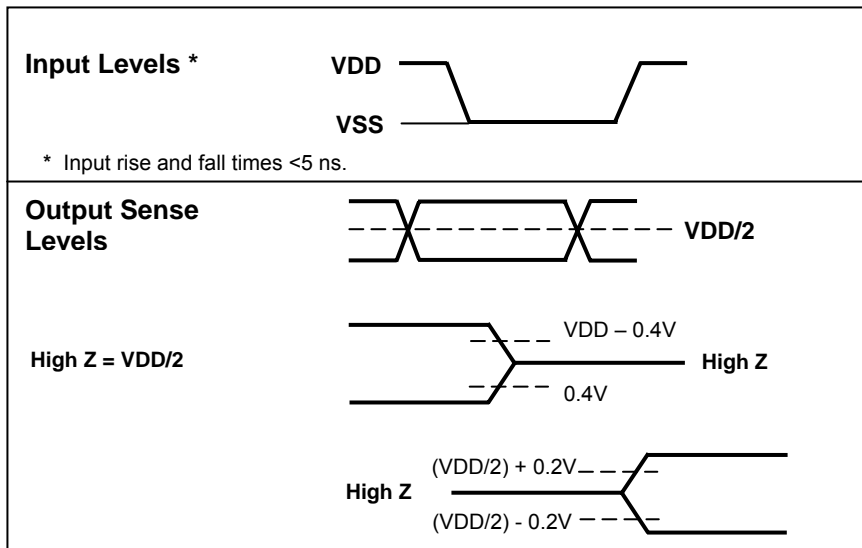

HX6408

ASYNCHRONOUS READ CYCLE AC TIMING CHARACTERISTICS (1)

Symbol	Parameter	Typical (2)	Worst Case (3)		Units
			-55 to 125°C		
			Min	Max	
TAVAVR	Address Read Cycle Time 300KRad 300kRad and 1MRad		20 25		ns
TAVQV	Address Access Time 300KRad 300kRad and 1MRad			20 25	ns
TAXQX	Address Change to Output Invalid Time (4)		5		ns
TSLQV	Chip Select Access Time 300KRad 300kRad and 1MRad			20 25	ns
TSLQX	Chip Select Output Enable Time (4)		4		ns
TSHQZ	Chip Select Output Disable Time (4)			4	ns
TPHQV	Sleep Enable Access Time			25	ns
TPHQX	Sleep Enable Output Enable Time		5		ns
TPLQZ	Sleep Enable Output Disable Time			10	ns
TGLQV	Output Enable Access Time			5	ns
TGLQX	Output Enable Output Enable Time (4)		0.5		ns
TGHQZ	Output Enable Output Disable Time (4)			3	ns

- (1) Test conditions: input switching levels, $V_{IL}/V_{IH}=0V/3V$, input rise and fall times <1 ns/V, input and output timing reference levels shown in the Tester AC Timing Characteristics table, capacitive output loading $C_L \geq 50$ pF, or equivalent capacitive output loading $C_L=5$ pF for TSHQZ, TPLQZ TGHQZ. For $C_L > 50$ pF, derate access times by 0.02 ns/pF (typical).
- (2) Typical operating conditions: $V_{DD}=3.3V$, $T_A=25^\circ C$, pre-radiation.
- (3) Worst case operating conditions: $V_{DD}=3.0V$ to $3.6V$, $T_A=-55^\circ C$ to $125^\circ C$, post total dose at $25^\circ C$.
- (4) These parameters can be tested as pass/fail.

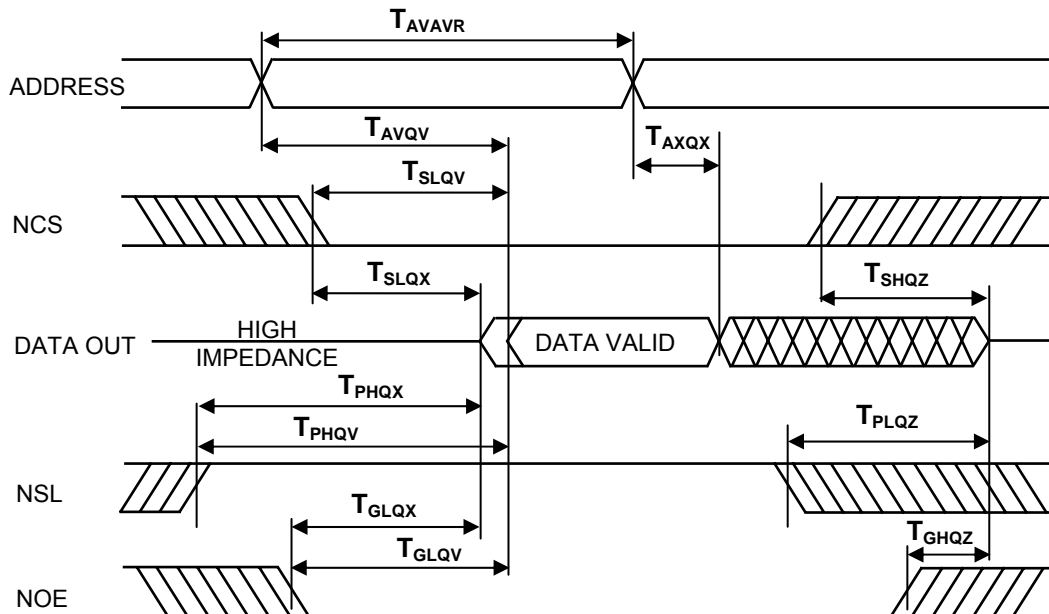

HX6408

Precharge Pulse on Data Outputs

Precharge Pulses are narrow pulses on the data output pins when a user may expect it to be a “low” logic condition during a READ cycle. During the start of each Read operation, two actions take place: the internal data bus is pre-charged to a high state (regardless of the previous value) and then the output latch is opened. Since the latch is opened at the start

of the Read operation, the internal “high” pre-charge value will show up at the output. This will only be apparent on Reads of two “low” values (low to low). Please read the Application Note **AN312 Data Output Precharge Pulse Condition** for detailed timing information and mitigation actions.

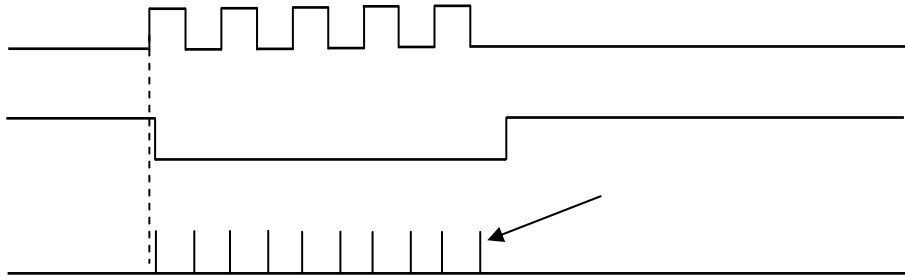

Pre-Charge Pulses on the Data Output pins - Memory Data is all “0s”.

Precharge Pulses on Data Outputs after Address bits transition when NOE is kept low for entire cycle.

ASYNCHRONOUS WRITE CYCLE AC TIMING CHARACTERISTICS (1)

Symbol	Parameter	Typical (2)	Worst Case (3) -55 to 125°C		Units
			Min	Max	
			TAVAVW	Write Cycle Time (4) 300KRad 300kRad and 1MRad	
TWLWH	Write Enable Write Pulse Width 300KRad 300kRad and 1MRad		15 25		ns
TSLWH	Chip Select to End of Write Time 300KRad 1MRad		16 20		ns
TDVWH	Data Valid to End of Write Time 300KRad 1MRad		12 15		ns
TAVWH	Address Valid to End of Write Time 300KRad 1MRad		20 25		ns
TWHDX	Data Hold after End of Write Time (6)			0.5	ns
TAVWL	Address Valid Setup to Start of Write Time (6)			1.5	ns
TWHAX	Address Valid Hold after End of Write Time (6)			3	ns
TWLQZ	Write Enable to Output Disable Time (6)			6	ns
TWHQX	Write Disable to Output Enable Time (6)		6		ns
TWHWL	Write Disable to Write Enable Pulse Width (5)		5		ns
TPHWH	Sleep Disable to Write Disable Time		25		ns

(1) Test conditions: input switching levels, VIL/VIH=0V/3V, input rise and fall times <1 ns/V, input and output timing reference levels shown in the Tester AC Timing Characteristics table, capacitive output loading ≥50 pF, or equivalent capacitive load 5 pF for TWLQZ.

(2) Typical operating conditions: VDD=3.3V, TA=25°C, pre-radiation.

(3) Worst case operating conditions: VDD=3.0V to 3.6V, -55°C to 125°C, post total dose 25°C

(4) TAVAVW = TWLWH + TWHWL

(5) Guaranteed but not tested.

(6) These parameters can be tested as pass/fail.

HX6408

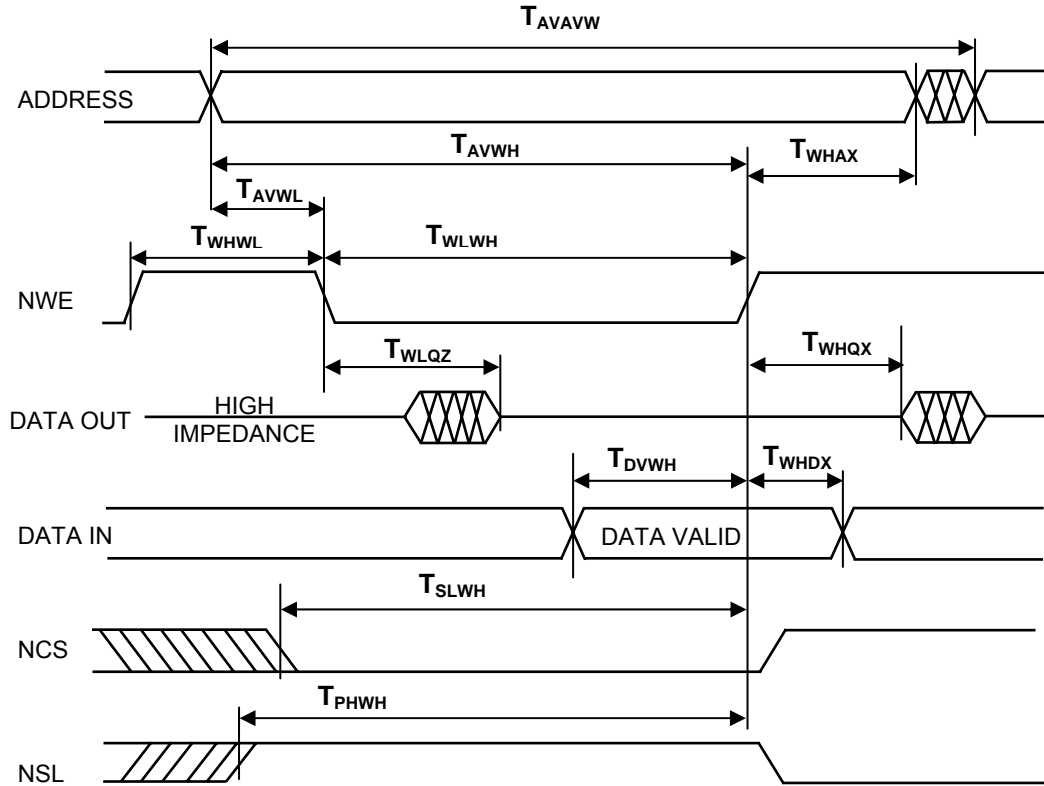

DYNAMIC ELECTRICAL CHARACTERISTICS

Asynchronous Operation

The RAM is asynchronous in operation. Read and Write cycles are controlled by NWE, NCS, NSL, and Address signals.

Read Operation

To perform a valid read operation, both chip select and output enable (NOE) must be low and not sleep (NSL) and write enable (NWE) must be high. The output drivers can be controlled independently by the NOE signal.

To perform consecutive read operations, NCS is required to be held continuously low, NSL held continuously high, and the toggling of the addresses will start the new read cycle.

It is important to have the address bus free of noise and glitches, which can cause inadvertent read operations. The control and address signals should have rising and falling edges that are fast (<5 ns) and have good signal integrity (free of noise, ringing or steps associated reflections).

For an address activated read cycle, NCS and NSL must be valid prior to or coincident with the address

edge transition(s). Any amount of toggling or skew between address edge transitions is permissible; however, data outputs will become valid T_{AVQV} time following the latest occurring address edge transition. The minimum address activated read cycle time is T_{AVAV} . When the RAM is operated at the minimum address activated read cycle time, the data outputs will remain valid on the RAM I/O until T_{AXQX} time following the next sequential address transition.

To control a read cycle with NCS, all addresses and NSL must be valid prior to or coincident with the enabling NCS edge transition. Address or NSL edge transitions can occur later than the specified setup times to NCS; however, the valid data access time will be delayed. Any address edge transition, which occurs during the time when NCS is low, will initiate a new read access, and data outputs will not become valid until T_{AVQV} time following the address edge transition. Data outputs will enter a high impedance state T_{SHQZ} time following a disabling NCS edge transition.

To control a read cycle with NSL, all addresses and NCS must be valid prior to or coincident with the enabling NSL edge transition. Address or NCS edge

HX6408

transitions can occur later than the specified setup times to NSL; however, the valid data access time will be delayed. Any address edge transition, which occurs during the time when NSL is high will initiate a new read access, and data outputs will not become valid until TAVQV time following the address edge transition. Data outputs will enter a high impedance state TPLQZ time following a disabling NSL edge transition.

Write Operation

To perform a write operation, both NWE and NCS must be low, and NSL must be high.

Consecutive write cycles can be performed by toggling one of the control signals while the other remains in their "write" state (NWE or NCS held continuously low, or NSL held continuously high). At least one of the control signals must transition to the opposite state between consecutive write operations.

The write mode can be controlled via three different control signals: NWE, NCS, and NSL. All three modes of control are similar, except the NCS and NSL controlled modes actually disable the RAM during the write recovery pulse. NSL fully disables the RAM decode logic and input buffers for power savings. Only the NWE controlled mode is shown in the table and diagram on the previous page for simplicity; however, each mode of control provides the same

write cycle timing characteristics. Thus, some of the parameter names referenced below are not shown in the write cycle table or diagram, but indicate which control pin is in control as it switches high or low. To write data into the RAM, NWE and NCS must be held low and NSL must be held high for at least WLWH/TSLSH/TPHPH time. Any amount of edge skew between the signals can be tolerated, and any one of the control signals can initiate or terminate the write operation. The DATA IN must be valid TDVWH time prior to switching high.

For consecutive write operations, write pulses (NWE) must be separated by the minimum specified WHWL/TSHSL/TPLPL time. Address inputs must be valid at least TAVWL/TAVSL/TAVPH time before the enabling NWE/NCS/NSL edge transition, and must remain valid during the entire write time. A valid data overlap of write pulse width time of TDVWH/TDVSH/TDVPL, and an address valid to end of write time of TAVWH/TAVSH/TAVPL also must be provided for during the write operation. Hold times for address inputs and data inputs with respect to the disabling NWE/NCS/NSL edge transition must be a minimum of TWHAX/TSHAX/TPLPX time and TWHDX/TSHDX/TPLDX time, respectively. The minimum write cycle time is TAVAV.

QUALITY AND RADIATION HARDNESS ASSURANCE

Honeywell maintains a high level of product integrity through process control, utilizing statistical process control, a complete "Total Quality Assurance System," a computer data base process performance tracking system and a radiation-hardness assurance strategy.

The radiation hardness assurance strategy starts with a technology that is resistant to the effects of radiation. Radiation hardness is assured on every wafer by irradiating test structures as well as SRAM product, and then monitoring key parameters, which are sensitive to ionizing radiation. Conventional MIL-STD-883 TM 5005 Group E testing, which includes total dose exposure with Cobalt 60, may also be performed as required. This Total Quality approach ensures our customers of a reliable product. It starts with process development and continuing through product qualification and screening.

SCREENING LEVELS

Honeywell offers several levels of device screening to meet your system needs. "Engineering Devices" are available with limited performance and screening for operational evaluation testing. As a QML supplier, Honeywell also offers QML Class Q and V devices per MIL-PRF-38535 and are available per the applicable Standard Microcircuit Drawing (SMD). QML devices offer ease of procurement by eliminating the need to create detailed specifications and offer benefits of improved quality and cost savings through standardization. The HX6408 is available per Standard Microcircuit Drawing (SMD) 5962-06203.

HX6408

RELIABILITY

Honeywell understands the stringent reliability requirements for space and defense systems and has extensive experience in reliability testing on programs of this nature. This experience is derived from comprehensive testing of VLSI processes. Reliability attributes of the SOI process were characterized by testing specially designed irradiated and non-irradiated test structures from which specific failure mechanisms were evaluated. These specific mechanisms included, but were not limited to, hot carriers, electromigration and time dependent dielectric breakdown. This data was then used to

make changes to the design models and process to ensure more reliable products.

In addition, the reliability of the SOI process and product in a military environment is monitored by testing irradiated and non-irradiated circuits in accelerated dynamic life test conditions. Packages were qualified for product use after undergoing Groups B & D testing as outlined in MIL-STD-883, TM 5005, Class S. Quality conformance testing is performed as an option on all production lots to ensure the ongoing reliability of the product.

PACKAGING

The 512K x 8 SRAM is offered in a commercially compatible 36-lead flat pack. This package is constructed of multi-layer ceramic (Al_2O_3) and contains internal power and ground planes. Parentheses denote pin options. These pins are available as NC to conform to commercial standards. All NC (no connect) pins should be connected to VSS to prevent charge build up in the radiation environment.

This SRAM is also offered as a Known Good Die (KGD). These parts are fully tested and screened and delivered in die form. KGD are often stacked or integrated with other chips into multi-chip modules to reduce the overall size of the electronics.

KGD may contain stub bonds and require compound wire bonding.

PACKAGE OUTLINE

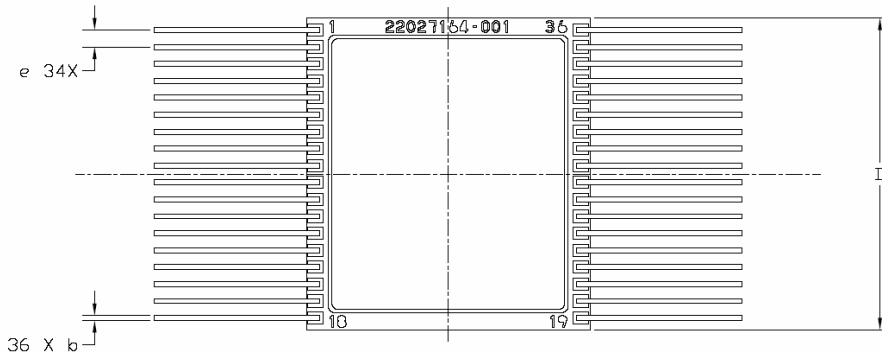

COMMON DIMENSIONS

SYM	MIN.	NOM.	MAX.
A	.102	.113	.125
A1	.085	.095	.105
B	.016	.018	.020
C	.004	.006	.008
D	.910	.920	.930
E	.045	.050	.055
E1	.832	.840	.848
L	----	.450	----
Q	----	.104	----

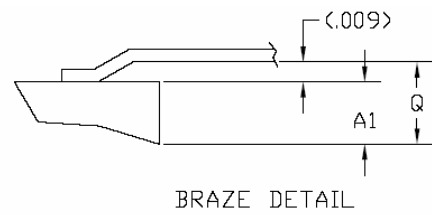
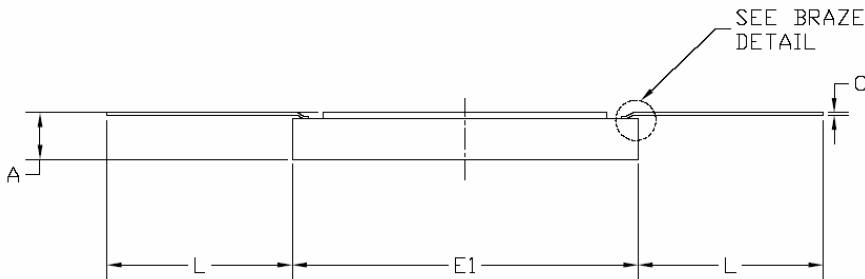

HX6408

ORDERING INFORMATION (1) (4)

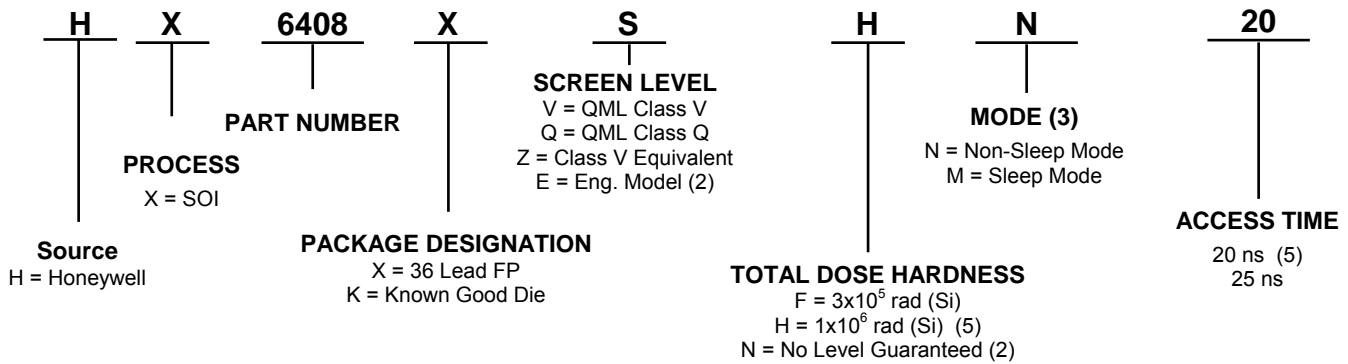

- (1) Orders may be faxed to 763-954-2051. Please contact our Customer Service Representative at 1-800-323-8295 for further information.
- (2) Engineering Device Description: Parameters are tested -55°C to 125°C, 24 hour burn-in, no radiation Guaranteed.
- (3) With the Non-Sleep Mode option, Pin 36 is a no-connect (NC), and is not wirebonded to the chip. With the Sleep Mode, Pin 36 has the NSL function.
- (4) The HX6408 is available per Standard Microcircuit Drawing (SMD) 5962-06203.
- (5) Total Dose Hardness Level H can only be procured with a 25ns Access Time.

FIND OUT MORE

For more information visit us online at www.honeywell.com/radhard.com or contact us at 800-323-8295 (763-954-2474 internationally).

Honeywell reserves the right to make changes to any products or technology herein to improve reliability, function or design. Honeywell does not assume any liability arising out of the application or use of any product or circuit described herein; neither does it convey any license under its patent rights nor the rights of others.

Honeywell