

REVISIONS				
ZONE	LTR	DESCRIPTION	DATE	APPROVED
	-	PRODUCTION RELEASE PER ECN #03-1036	09-18-03	D. S.
	A	REV PER ED #12095	08-11-05	R. J.

1. CONTROLLING DIMENSIONS ARE IN MILLIMETERS.
2. DISTANCE FROM THE BOTTOM CERAMIC EDGE TO THE HIGHEST POINT OF THE PACKAGE INCLUDES PACKAGE BODY THICKNESS A2 AND LID HEIGHT.
3. THE A-1 CORNER IS IDENTIFIED BY A SMALLER CHAMFER, A ROUND DOT ON THE TOP SURFACE, AND A SQUARE PAD ON THE BOTTOM SURFACE OF THE PACKAGE.
4. BILATERAL TOLERANCE ZONE IS APPLIED TO EACH SIDE OF THE PACKAGE BODY.
5. THIS PACKAGE USES LID 22025861-002.
6. DFOISR 05-S-1870.

REFERENCE ONLY COPY

QTY REQD	CODE IDENT	PART OR IDENTIFYING NO.	NOMENCLATURE OR DESCRIPTION	REMARKS	ITEM NO.
		T. WAGNER DRAFTSPERSON	9/16/03 DATE	HONEYWELL INC. SOLID STATE ELECTRONICS CENTER MINNEAPOLIS, MINNESOTA	
		CHECKER	DATE	472 LGA CASE OUTLINE, 1.27MM DRAWN LID	
		S. SPIELBERGER ENGINEERING AREA APPROVER	9/16/03 DATE		
		S. FLOLID AFFECTED AREA APPROVER	9/16/03 DATE	SIZE	CODE IDENT NO. DRAWING NO.
NEXT ASSY APPLICATION	USED ON	L. CHAMAS SRB APPROVER	9/16/03 DATE	B	34168 22026798
				SCALE	NONE SHEET 1 OF 2

September 08, 2005 10:38

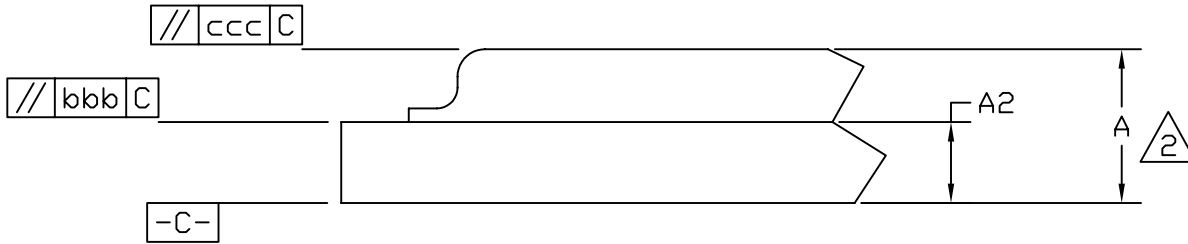

DETAIL A (ROTATED 90°)

DIM	MILLIMETERS			INCHES		
	MIN	NOM	MAX	MIN	NOM	MAX
A	-	3.20	3.53	-	.126	.139
A2	1.35	1.50	1.65	.053	.059	.065
b	.79	.84	.89	.031	.033	.035
<u>D</u> <u>E</u>	29.00			1.142		
<u>D1</u> <u>E1</u>	26.67			1.050		
<u>e</u>	1.27			0.050		
<u>S</u>	0.635			0.025		
aaa	0.29			0.011		
bbb	0.25			0.010		
ccc	0.35			0.014		
eee	0.35			0.014		
fff	0.30			0.012		

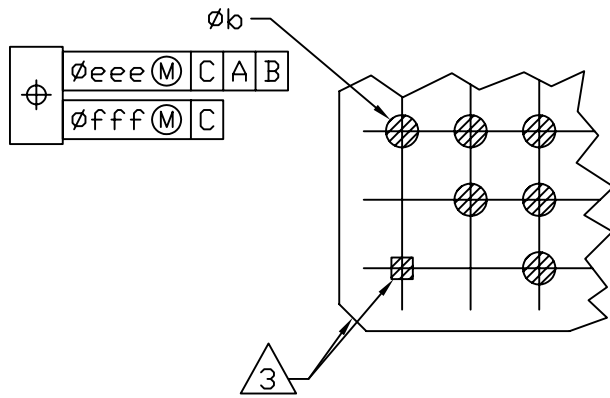

DETAIL B

REFERENCE ONLY COPY

SIZE	CODE IDENT NO.	DRAWING NO.
B	34168	22026798
SCALE	NONE	SHEET 2 OF 2