

Precision Pressure Transducer PPT

Honeywell's precision pressure transducer (PPT) offers extraordinary value with high accuracy over a wide temperature range. The PPT combines proven silicon sensor technology with microprocessor-based signal conditioning to provide an extremely smart pressure transducer. Available in a compact, rugged design, the PPT has many software features that support a wide range of applications.

APPLICATIONS:

- Secondary Air Data
- Altimeters
- Engine Testing
- Flight Testing
- Meteorology
- Flow and Pressure Calibrators
- Instrumentation and Analytical Equipment
- Process Control
- Research and Development

±0.05%
Accuracy from
-40 to 85°C

Digital and
Analog

Many
Software
Features



CE Qualified
ISO-9001
ISO-14001

FEATURES AND BENEFITS

- ▶ **High Accuracy**
±0.05% FS typical accuracy from -40 to 85°C
- ▶ **Smart, Digital Sensing and Control**
- ▶ **Versatile and Configurable**
- ▶ **User Selectable Software Features**
- ▶ **Simplifies System Design** - No additional signal compensation needed to gain the benefits of a very accurate sensor.
- ▶ **Efficient Data Acquisition** - Connect up to 89 units on a multidrop bus using built-in RS-485 capability.
Easy Interface - Directly connects to PC via communication ports.
Closes the Loop - Smart PPT makes control decisions.
- ▶ **Works with existing and new systems.** - All units have 0-5V analog and either RS-232 or RS-485 digital outputs.
Handles most dry gas media.
Optimizes Output - User-configurable pressure units, sampling, update rate.
Flags Problems - Internal diagnostics set flags, provide alarms.
- ▶ Baud Rate, Parity Setting, Continuous Broadcast, ASCII or Binary Output, Sensor Temperature Output (°C or °F), Deadband, Sensitivity, Tare Value, Configurable Analog Output

SPECIFICATIONS

Performance Specifications⁽¹⁾

Accuracy: (from -40 to 85°C)
 Digital: ±0.05% FS Typ., ±0.10% FS Max.⁽²⁾
 Analog: ±0.06% FS Typ., ±0.12% FS Max.⁽²⁾
 Temperature: ±1°C (at sensing element)
Temperature Range:
 Operating -40 to 85°C (-40 to 185°F)
 Storage: -55 to 90°C (-67 to 194°F)
Sample Rate⁽⁵⁾: 8.33ms to 51.2 min
Resolution:
 Digital: Up to 0.0011% FS
 Analog: 1.22mV steps (12 bits)
Response Delay:
 (1000/update rate) +1ms, minimum 17ms
Long Term Stability⁽⁷⁾: 0.025%/FS max per year

Mechanical Specifications

Pressure Ranges and Type:
 See Ordering Information
Pressure Units⁽⁶⁾: atm, bar, cmwc, ftwc, hPa, inHg, inwc, kg/cm², KPa, mBar, mmHg, MPa, mwc, psi, user, lcom, pfs
Static Pressure (Differential Only) :
 ≤ 150psi: no effect on accuracy of PPT
 > 150psi: out of spec, returns spec ≤ 150psi
Media Compatibility: Suitable for non-condensing, non-corrosive, and non-combustible gases.
PPT available for other gases and fluids.
Weight: 5 oz. (142 gm) without fittings

Electrical Specifications

Output:
 RS-232 Digital w/0-5V Analog⁽⁵⁾
 RS-485 Digital w/0-5V Analog⁽⁵⁾
Power Requirements:
 Supply Voltage: 5.5 to 30 VDC
 Operating Current: Standard: 17-30mA; CE: 13-25mA
Baud Rate⁽⁶⁾: 1200, 2400, 4800, 9600, 14400, 19200, 28800
Bus Addressing⁽⁶⁾: Address up to 89 units

Environmental Features⁽³⁾

Overpressure: 3x FS, maximum 600psi
Burst Pressure: 3x FS, maximum 700psi
Mechanical Shock: 1500G, 0.5ms half sine
Temp Shock: 24 1-hour cycles, -40 to 85°C
Vibration: 0.5in or 20G's, 20Hz – 2K Hz

(1) Accuracy is the sum of worst case linearity, repeatability, hysteresis, thermal effects and calibration errors from -40 to 85°C. Typical is the average of absolute value of errors at all pressures and temperatures. Full scale for differential ranges is the sum of + and - ranges. Pressure range 1psi gauge has digital accuracy of ±0.10% FS typical, ±0.20% FS maximum; analog accuracy of ±0.12% FS typical, ±0.24% FS maximum. Calibration is traceable to NIST. (2) Tighter accuracy available on some models. Consult factory. (3) Exposure to overpressure will not permanently affect calibration or accuracy of unit. Burst pressure is the sum of the measured pressure plus the static pressure and exceeding it may result in media escape. Mechanical Shock tested per MIL-STD-883D, M2002.3, Cond. B. Vibration tested per MIL-STD-883D, M2007.2, Cond. A. (4) CE Mark per IEC 61326. See www.ssec.honeywell.com/pressure/datasheets.html for information on test levels and results. Connector MIL-C-26482, Shell Size #10, 6-pin #20 size. (5) User configurable. (6) Demonstration kit includes unit, power supply/data cable (120V), demonstration software, and user manual. (7) When continuously powered at 25±10°C, <90%RH and 28 to 32 inHg atmospheric pressure.

Find out more

For more information on Honeywell's Precision Pressure Transducers visit us online at www.pressuresensing.com or contact us at 800-323-8295 or 763-954-2474. Customer Service Email: ps.customer.support@honeywell.com.

Honeywell reserves the right to make changes to improve reliability, function or design. Honeywell does not assume any liability arising out of the application or use of any product or circuit described herein; neither does it convey any license under its patent rights nor the rights of others. Covered by one or more of the following US Patents: 4,918,992 and 4,788,521.

Honeywell
 12001 Highway 55
 Plymouth, MN 55441
 Tel: 800-323-8295
www.pressuresensing.com

CASE OUTLINE

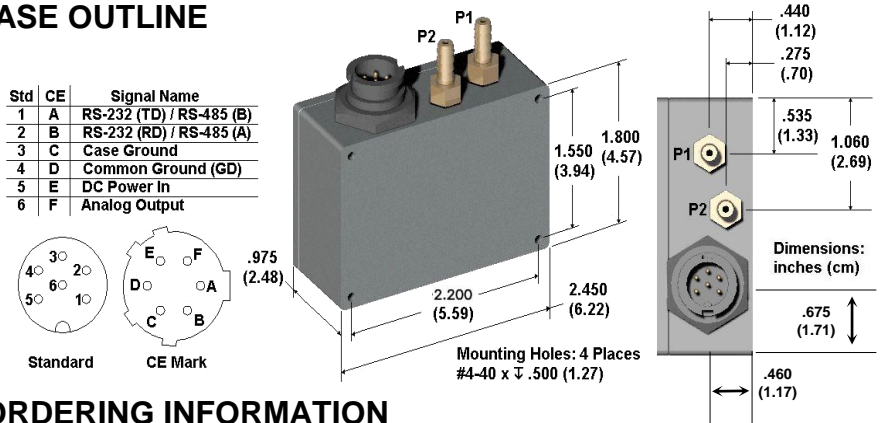

ORDERING INFORMATION

PPT Precision Pressure Transducer

FULL SCALE PRESSURE RANGE

	Absolute	Gauge	Differential
0001	n/a	1 PSI ⁽¹⁾	±1 PSI
0002	n/a	2 PSI	±2 PSI
0005	n/a	5 PSI	±5 PSI
0010	n/a	10 PSI	±10 PSI
0015	15 PSI	n/a	n/a
0020	20 PSI	20 PSI	±20 PSI
0050	50 PSI	50 PSI	±50 PSI
0100	100 PSI	100 PSI	±100 PSI
0300	300 PSI	300 PSI	±300 PSI
0500	500 PSI	500 PSI	±500 PSI

TYPE	P1 Pressure	P2 Pressure
A Absolute	0(vacuum) to FS	N/A
G Gauge	Reference to FS	Reference
D Differential	+FS to -FS rel. to P2	+FS to -FS rel. to P1

P1 PRESSURE CONNECTION

- W Absolute, Gauge, Differential Brass barbed (1/8 inch ID tubing)
- X Brass Swagelok™ (1/8 inch female)
- R Brass barbed, right angle (1/8 inch ID tubing)
- F Filter (blocks debris)

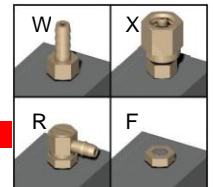

P2 PRESSURE CONNECTION

- Gauge, Differential
- W Brass barbed (1/8 inch ID tubing)
- X Brass Swagelok™ (1/8 inch female)
- R Brass barbed, right angle (1/8 inch ID tubing)
- F Filter (blocks debris)
- Absolute
- N Not Applicable

OUTPUTS

- 2V RS-232 digital, 0-5V analog
- 5V RS-485 digital, 0-5V analog

ELECTRICAL CONFIGURATION AND CONNECTION

- A Standard, 6-pin plastic connector
- B CE Mark⁽⁴⁾, 6-pin metal connector

OPTIONS

- A Demonstration Kit⁽⁶⁾ (RS-232 only)
- B Mating Connector (See Below)
- C Power Supply/Data Cable (RS-232 only, See Below)

PPT 0100 A W N 2V A -A

